

HULTDINS SuperGrip™

Features

- Optimized design that secures high quality and strength.
- Tapered sleeve pin design eliminates any joint motion.
- Strong cushioned cylinder to reduce shock loads for up to 25 MPa working pressure.
- High strength and reliability minimize stagnation time.
- Grapple saw option available on all models.

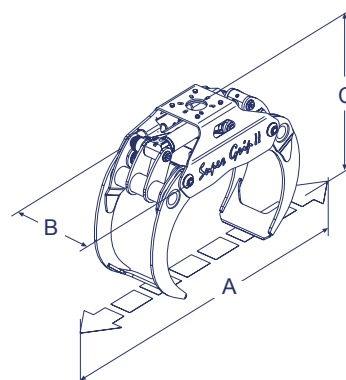

SuperGrip II

| | | 260S | 300S | 360S | 420S |
|---|----------------|-------|-------|-------|-------|
| Weight | kg | 200 | 205 | 320 | 348 |
| Max. load | kg | 4 000 | 4 000 | 5 000 | 5 500 |
| Gripping area, tip-tip | m ² | 0.26 | 0.30 | 0.36 | 0.42 |
| Gripping area, practical | m ² | 0.35 | 0.40 | 0.45 | 0.52 |
| Max. gripping width "A" | mm | 1 547 | 1 526 | 1 886 | 2 075 |
| Overall grapple width "B" | mm | 460 | 460 | 548 | 548 |
| Height, arms tip-tip "C" | mm | 878 | 915 | 980 | 1 061 |
| Max. height arms open | mm | 743 | 790 | 808 | 851 |
| Min. height arms closed | mm | 575 | 560 | 640 | 697 |
| Grapple jaw width | mm | 388 | 388 | 468 | 468 |
| Min. gripping diameter | mm | 110 | 110 | 150 | 180 |
| Gripping force, arms open, at 25 MPa | kN | 12.0 | 12.0 | 19.0 | 20.2 |
| Gripping force, arms tip-tip, at 25 MPa | kN | 14.3 | 14.3 | 19.0 | 24.3 |
| Opening time, at 50 l/min | s | 1.0 | 1.0 | 1.8 | 2.6 |
| Closing time, at 50 l/min | s | 1.7 | 1.7 | 2.5 | 3.5 |
| Max. operating pressure | MPa | 25 | 25 | 25 | 25 |

0107-7000561-EN



Hultdin System AB, Skolgatan 12, SE-930 70 Malå, Sweden
 Phone: +46 953 418 00, Fax: +46 953 418 01, E-mail: sales@hultdins.se
www.hultdins.se